

## FlexMEA36-OM

FlexMEA36-OM for use with ME2100- $\mu$ PA32 and via connector MCS\_ADPT-ME2100-HS32-OM also usable for ME2100-HS32-M-3m. Not compatible with in vitro MEA2100-Systems.



### Technical Specification

General Characteristics	
Temperature compatibility	10 - 50 °C
Dimensions (W x D x H)	45 mm x 13.8 mm x 1.8 mm
FlexMEA36 Layout	
Thickness of the electrode field	12 $\mu$ m
Base material	Polyimide 2611 foil
Weight	< 1 g
Track material and contact pads	Gold (Au)
Electrode diameter	30 $\mu$ m
Interelectrode distance (center to center)	300 $\mu$ m
Diameter of the holes	50 $\mu$ m
Electrode height	Planar
Electrode material	TiN electrodes (Titanium nitride)
Isolation material	Polyimide 2611 foil
Electrode impedance	< 150 k $\Omega$
Electrode layout grid	6 x 6
Number of recording electrodes	32
Number of reference electrodes	2
Number of ground electrodes	2
Software	Multi Channel Experimenter: linear
Cleaning and Sterilization	
Cleaning	Rinse with distilled water, optional with ethanol 70 %
Sterilization	Do not autoclave or sterilize FlexMEAs by heat. These MEA types are not heat-stable and will be irreversibly damaged! Please do not use ultrasonic bath for cleaning.

## FlexMEA36-OM: Electrode Layout

Electrode Layout (electrodes facing down, seen from behind, please see the picture beside)

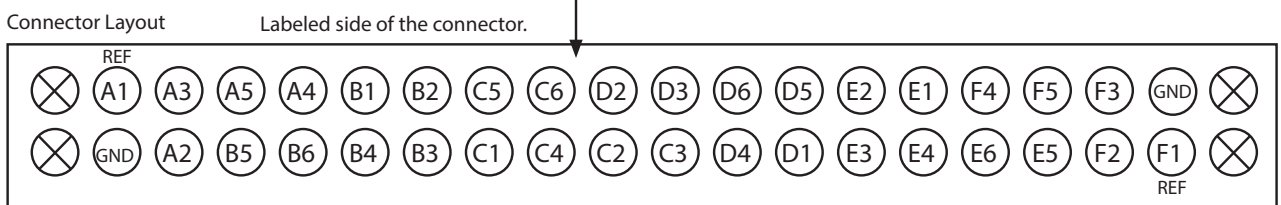
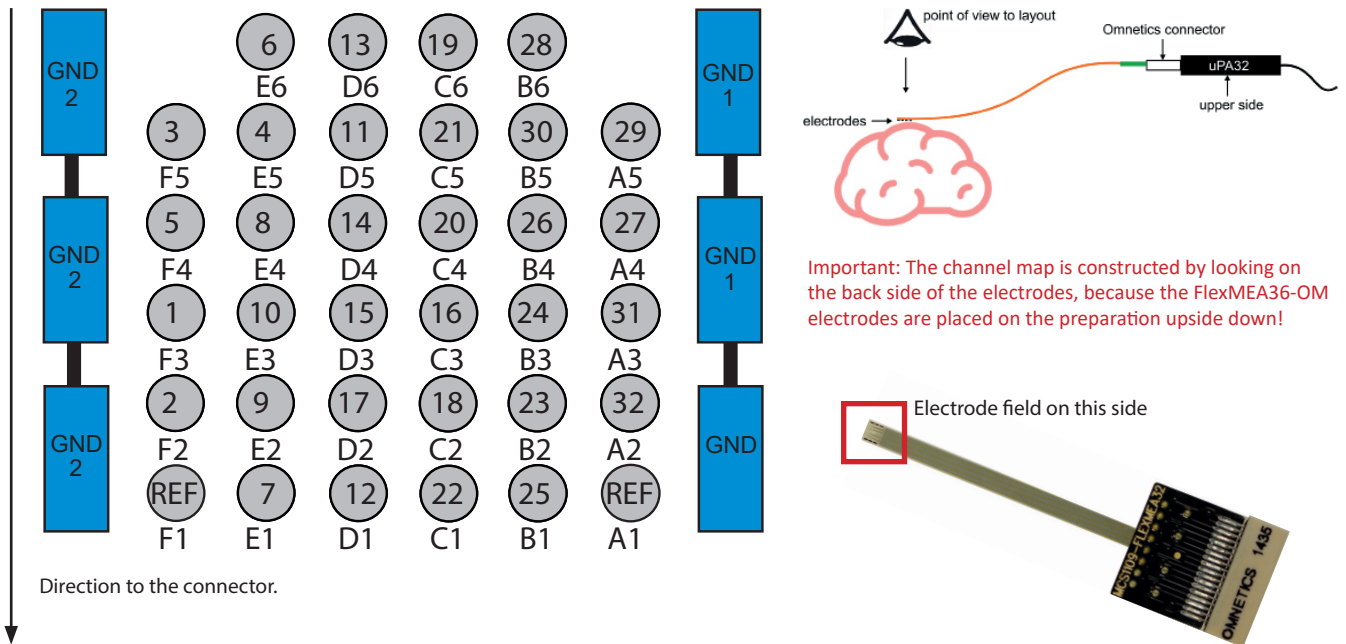

### Technical Specifications of the FlexMEA36-OM

Numbering	The letter digit code below the electrode refers to the position of the electrode in the grid. The numbers inside are the linear channel numbers in Multi Channel Experimenter and MC_Rack.
Multiple Headstages	MC_Rack : If you use more than one $\mu$ PA32, the signal collector SC2x32 leads the output channels of the second amplifier to channel number 33 - 64. Please see datasheet SC2x32 for details. Multi Channel Experimenter: If you use a ME2100-System with more than one headstage, the second/third/fourth headstage will be displayed as channels B1 - B32 / C1 - C32 / D1 - D32.
Connector Specification	Manufacturer: Omnetics Manufacturer Type and Part No: NDP-36-DD-GS and A79022-001 Connector with 36 pos, dual row, male, provided with 4 holes for guide posts. <span style="float: right;">Guide post </span>